

# Series 'A' Roller Door Installation Instructions



**TAUREAN DOOR SYSTEMS**

Phone (03) 9721 - 8366

[www.taureands.com.au](http://www.taureands.com.au)

**Extreme safety warning.** Safe practices must be observed when working at heights, lifting roller doors and adjusting roller door spring tension.

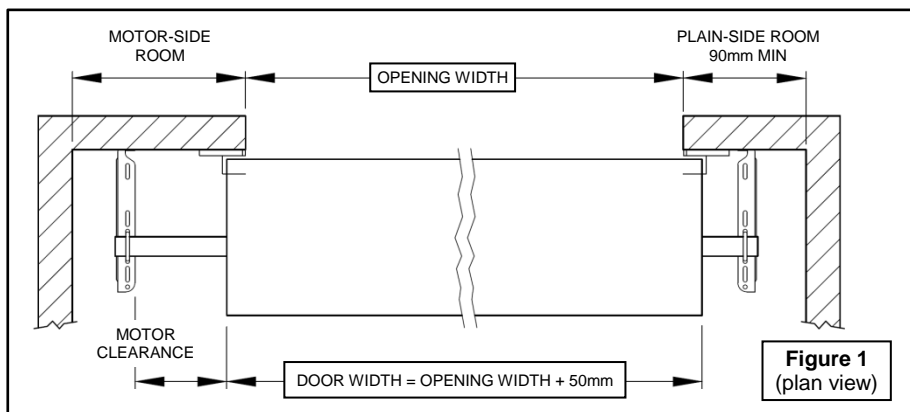

1. Check DOOR WIDTH against OPENING WIDTH (Figure 1). For a standard (non-windlocked) installation the roller door curtain should be at least 50mm wider overall than the opening. For windlocked installation side room increases by 35mm each end and DOOR WIDTH = OW + 100mm. For WINDSTRONG® refer to supplemental instructions.

2. Check SIDE-ROOM (Figure 1). If a motor is to be installed, ensure there is also enough clearance between edge of curtain and bracket (refer to manufacturer’s instructions).

3. Check the HEAD-ROOM **B** and BACK-ROOM **E** (Figure 2 and Table 1).

4. Mark the horizontal position for the wall brackets. They should be positioned well clear of the curtain edge, guide tracks, and any track brackets. The flanges normally point towards the roller door.

5. Mark the vertical position of the wall brackets above the opening (Figure 2 **D**). Level the two brackets at the door mounting faces using a water level or other suitable device.

6. Attach the wall brackets to the wall:

- Only self-drilling screws and wood fixing screws are supplied in the kit box (no expanding or masonry bolts). The installer must assess what is appropriate in each situation.
- If welding installer must verify weld integrity and strength.
- If screw fastened:
  - For steel purlins: four or more self-drilling screws must be used to secure each bracket.
  - For timber frame: three or more 8mm x 50mm coach screws must be used per bracket.
  - For brick or concrete: depending on the type and condition of the wall, use three or more long M8 bolts (or threaded rod) from the outer surface of the wall, or 10mm (M8 thread) metal expansion fasteners ( eg Loxin or Dynabolt).
- Flat washers must be used under all nuts and all bolt and screw heads.
- A screw or bolt must be fitted to the very top slot. Select other slot positions evenly spaced up the bracket flange as required.

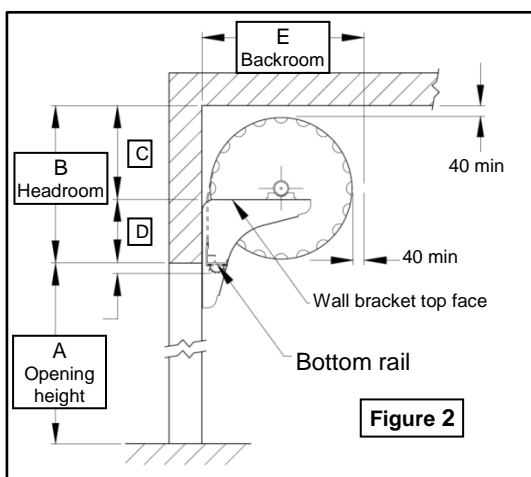

Table 1		MOUNTING ROOM (mm)				
A	B	C	D	E		
1200	430	265	165	450		
2200	440	270	170	475		
2500	455	275	180	495		
2800	485	295	190	505		
3100	495	300	195	515		

7. Option: mount motor loosely onto the axle at the required end (the coloured side of the door faces outwards).

8. Centre the axle by rotating a ¼ turn then releasing. Mark the axle where the drum wheel sits in the relaxed state. There should be an equal length of axle at each end.

- Lift the roller door onto the brackets and loosely secure the axle to the brackets using two 'U' bolts and saddles. The motor may have its own internal 'U' bolt to clamp the axle.

**Extreme safety warning.** Safe practices must be observed when lifting roller doors as they can be very heavy. The installer must ensure the roller door is secure and supported at all times. The door is to be placed onto both brackets at the same time. The wall brackets are designed to support only a horizontal door and using them to mount door lifting gear is **not** recommended by Taurean. Any injury or damage arising from this practice will be the installer's responsibility and is **not** covered by the door warranty.

- Centre the roller door on the axle with the same amount of curtain overlap at each side of the opening and position the motor. Rocking the roller door on its axle will assist the door to move into position. Ensure the drum sits on the axle as marked in Step 8.
- Move the door to the rear of the bracket slots and, without cutting the centre nylon strap, remove other strapping and packaging material.
- Turn the axle to allow the door to be relaxed on the axle with the bottom rail at the bottom of the curtain (6 o'clock position) then fully tighten the two 'U' bolts to clamp the axle to the brackets.
- Apply 1 turn of spring pre-tension by turning the curtain roll 1 turn over the top and hold in this

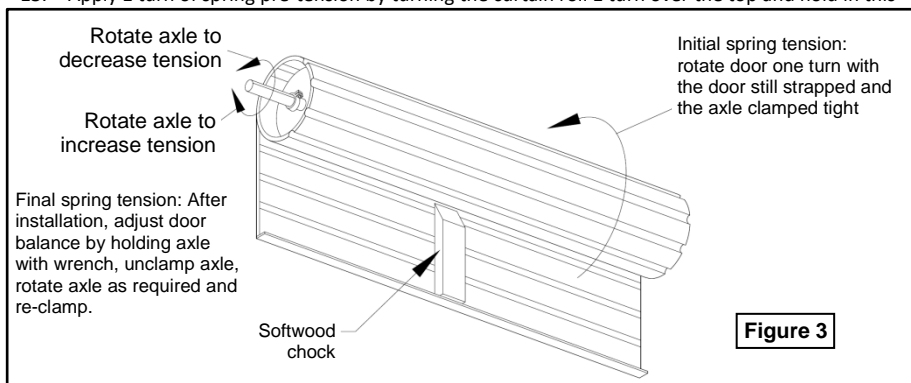

position (Figure 3).

- Without letting go of the curtain, cut the centre strap and remove packaging. Holding the centre of the bottom rail, the curtain may now be fully opened and closed to ensure the roller door is rolling up in correct alignment on the roll (ie, the ends of the rolled curtain must be square and not 'coned') prior to fitting the Guide Tracks. Take care to avoid the nylon braiding or the door curtain touching the wall.
- The door should have a small amount of lift when in the open position and so a softwood chock may now be carefully positioned (Figure 3) between the Bottom Rail and the curtain roll to prevent the door rolling up.

- Cut the bottom of the tracks to suit the opening height. The underside of the top stop is normally level with the top of the opening (Figure 2). The weather seal will protrude ~20mm into the opening when the door is open. The top of the track should be at or above the wall bracket, otherwise bend the sharp top edge of the track away so that it can't damage the nylon braiding.
- Flare out both the side and rear faces at the track lead-in (Figure 4). After fitting the tracks, if necessary adjust the angles so the curtain enters the track smoothly.

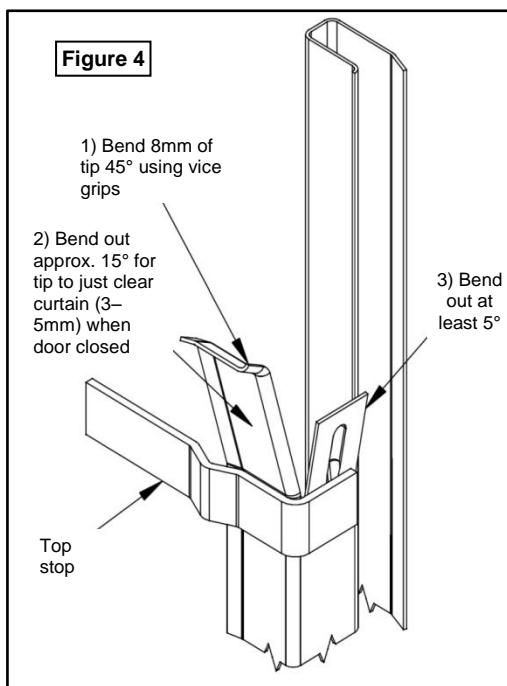

- Insert the supplied track mounting brackets into the smaller 'U' profile of the tracks. Space them out in appropriate positions along the tracks, allowing enough room at the top of the tracks to not interfere with the Wall Brackets.

19. Mount the tracks to the wall. Lower the door to the closed position and slide the tracks in from the side until there is a 3-6mm gap between the track and the black plastic button at the end of the Bottom Rail. Ensure the tracks are vertical then fix to the wall by screwing or welding as appropriate.
20. **Note:** Before fully fastening the tracks, operate the door fully to ensure it is not binding in the tracks at any point.
21. Adjust the door-axle to the optimal position on the mounting brackets. Work with the door in the open position and only loosen one end at a time. Loosen the 'U' bolt and move the door towards the wall until just about touching the track front face but avoiding any binding. Ensure both 'U' bolts are fully re-tightened.

22. Install both of the optional top stop catcher brackets (Figure 5) at each end of the bottom rail using the supplied dome-head bolt and nut. Mark using the bracket as a guide and drill.

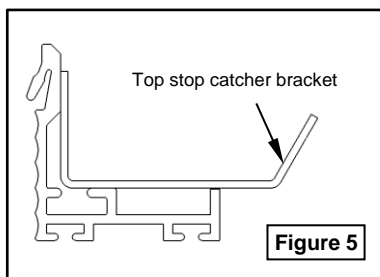

23. Check the door balance:

When correctly balanced, the roller door should have a tendency to lift slightly at the top and bottom positions and be neutral or slightly heavy at mid height.

24. If necessary, adjust the springs (Figure 3):

With the door in the open position, loosen one 'U' bolt. Then, while preventing the axle from turning with a pipe wrench, loosen the other 'U' bolt. The handle of the wrench will want to lift towards the ceiling. Turn the axle in the direction required to adjust the spring tension: raise the wrench make the door 'heavier', lower to 'lighten'. This is a potentially hazardous step and should only be attempted by a competent tradesperson. Ensure both 'U' bolts are fully re-tightened before operating door.

25. Complete motor installation and setup to the manufacturer's instructions.

26. Fit the optional centre lock. Remove the protective film from this area, position the lock front in the panel holes and hold or tape to the outside of the door. From the back of the door, orient the lock with the writing the 'right way up' and screw to the lock front with the 2 screws supplied.

With the door in the fully closed position, mark the height positions of the locking bar and cut a hole in each track for the locking bars to slide through.

With the lock arms fully retracted, temporarily fit the 2 locking bars to the lock arms then mark the correct length. Cut each bar to length and chamfer-cut the corners for a lead-in. Then install the locking bars through the PVC guides ensuring that any supplied anti-rattle grommets are fitted and screw them to the lock arms. Check the lock operation.

27. Remove the protective film from the outside face of the curtain.

## Product Warranty

# Stramit Corporation Pty Limited Roller Door Warranty and Exclusion of Liability Statement

1. This Warranty is given by:

Stramit Corporation Pty Limited trading as Taurean Door Systems  
(**Taurean**) Level 4, 68 Waterloo Rd, Macquarie Park NSW 2113  
Phone: (03) 9721 8366  
Email:  
customerservice@taureands.com.au  
Website: www.taureands.com.au

on Taurean® roller door kits (**Product**) for a **twelve-month** period from the date of purchase of the Product, against defects which is subject to the matters set out below (**Warranty**).

2. The Warranty is in addition to your rights and remedies that may be available to consumers under the Australian Consumer Law.
3. If you are a consumer, as defined under the Australian Consumer Law, our goods come with guarantees that cannot be excluded under the Australian Consumer Law. You are entitled to a refund for a major failure and compensation for any other reasonably foreseeable loss or damage. You are also entitled to have the goods repaired or replaced if the goods fail to be of acceptable quality and the failure does not amount to a major failure.
4. This Warranty applies only where:
  - (a) the purchaser seeking to rely on the Warranty presents proof of purchase to confirm the date of purchase of the Product;
  - (b) if the Product has been installed, an authorised Taurean installer (Authorised Installer) performed the installation; and
  - (c) Taurean determines, in its absolute discretion, that the Product has a defect covered by this Warranty.
5. Your Product Warranty does not apply to any defect, loss or damage arising through or caused directly or indirectly by, or as a result of:
  - (a) fair wear and tear (e.g. working seals in the inlet and outlet valves, scratching from cleaning, paint rubs or scuffing on the internal wash coat finish or external painted finish etc.);
  - (b) Any defects or deterioration of timber, including drying, after installation of the Product;
  - (c) Any weakening, cracking, deterioration, or collapse of the structure or surface, during installation or use, to which the Product is (or is intended to be) affixed;
  - (d) incorrect storage or handling of the Product after delivery;
  - (e) failure to properly install, use or maintain the Product, or to follow any instructions or guidelines for installation, use or maintenance of the Product, including carrying out regular servicing or preventative maintenance;
  - (f) The continued use or operation of the Product after any defect becomes apparent, or would have become apparent to a reasonably prudent operator or user;
  - (g) Installation, adjustment or use of the Product, other than by Taurean or an Authorised Installer;
  - (h) Attempted or completed modifications or repairs to the Product carried out by a person who is not authorised by Taurean to

- carry out such modifications or repairs;
- (i) the use of the Product, within 800 metres of the sea or other body of water of equivalent or greater salt concentration or in an area subject to chemical or industrial fall out, or otherwise than for any application specified on a quote or order form, price book or catalogue issued by Taurean; or
  - (j) any accident or act of God.
6. To make a valid claim under this Warranty, a person must submit a claim in writing to Taurean at the abovementioned address **within twelve months** from the date of purchase of the Product. The claim must include:
- (a) A copy of this Warranty;
  - (b) A description and evidence of (e.g. photo) how the Product is defective;
  - (c) The date on which the person making the claim discovered the defect;
  - (d) Proof of the date of purchase of the Product in the form of an invoice or receipt; and
  - (e) If the Product has been installed, proof of the date of installation of the Product in the form of an invoice or receipt from an Authorised Installer.
7. Where a valid Warranty claim is made in accordance with clause 6 above, Taurean will investigate the claim, and requires reasonable and adequate access to Products, to undertake its investigation. If a Warranty service call finds that your Product does not have a genuine manufacturing defect, or the claim is resolved by a regular service (that comes under the responsibility of the purchaser) Taurean reserves the right to charge you a service fee.
8. To the fullest extent permitted by law, Taurean expressly excludes all conditions, warranties and undertakings in relation to the Products except as set out in this document.
9. To the fullest extent permitted by law, and subject to and without limiting your consumer rights under the Australian Consumer Law, Taurean expressly limits its liability under this Warranty and under any other statutory guarantee imposed at law to, at its absolute discretion:
- (a) Replacing or repairing the Product;
  - (b) The supply of an equivalent Product; or
  - (c) the payment of the cost of the Product, or of repairing the Product, or of acquiring an equivalent Product.
10. This Warranty is not transferrable, and only applies to the original purchaser. Wherever the Product is sold by any person other than Taurean, such person has no authority whatsoever from Taurean to give any express warranty or guarantee on any Taurean product in addition to this Warranty.