

Series 'B' Roller Door Installation Instructions



TAUREAN DOOR SYSTEMS

Phone (03) 9721 - 8366

www.taureands.com.au

Extreme safety warning. Safe practices must be observed when working at heights, lifting roller doors and adjusting roller door spring tension.

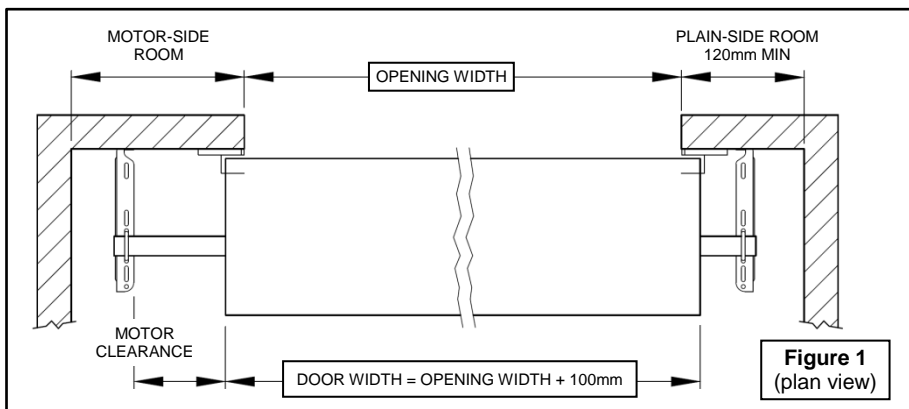

1. Check DOOR WIDTH against OPENING WIDTH (Figure 1). For a standard (non-windlocked) installation the roller door curtain should be at least 100mm overall wider than the opening. For windlocked installation side room increases by 35mm each side. For WINDSTRONG® refer to supplemental instructions.
2. Check SIDE-ROOM (Figure 1). If a motor is to be installed, ensure there is also enough clearance between edge of curtain and bracket (refer to manufacturer's instructions). Chain-operators (direct-drive or planetary-gear) require 90mm MOTOR CLEARANCE and 195mm MOTOR SIDE ROOM.

3. Check the min. HEAD-ROOM **B** and BACK-ROOM **E** (Figure 2 and Table 1).
4. Mark the horizontal position for the wall brackets. They should be positioned well clear of the curtain edge, guide tracks, and any track brackets. The flanges normally point towards the roller door.
5. Mark the vertical position of the wall brackets above the opening (Figure 2 **D**). Level the two brackets at the door mounting faces using a water level or other suitable device.

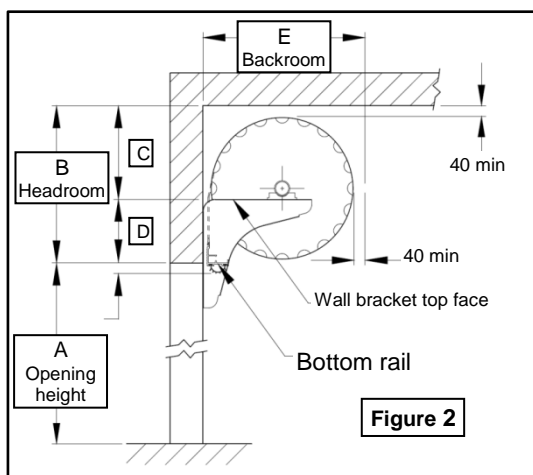

6. Attach the wall brackets to the wall:
 - Only self-drilling screws and wood fixing screws are supplied in the kit box (no expanding or masonry bolts). The installer must assess what is appropriate in each situation.
 - If welding installer must verify weld integrity and strength.
 - If screw fastened:
 - For steel purlins: four or more self-drilling screws must be used to secure each bracket.
 - For timber frame: three or more 8mm x 50mm coach screws must be used per bracket.
 - For brick or concrete: depending on the type and condition of the wall, use three or more long M8 bolts (or threaded rod) from the outer surface of the wall, or 10mm (M8 thread) metal expansion fasteners (eg Loxin or Dynabolt).
 - Flat washers must be used under all nuts and all bolt and screw heads.
 - A screw or bolt must be fitted to the very top slot. Select other slot positions evenly spaced up the bracket flange as required.
7. Option: mount motor loosely onto the axle at the required end (the coloured side of the door faces outwards) with the drive disengaged.
8. If installing a chain-operator (direct-drive or planetary-gear), bolt the chain wheel (or plastic ring gear) to the drum wheel at the correct end of the door using the 3 bolts, nuts, and washers provided. If door is windlocked the chain-operator is spaced 34mm further out from the drum

Table 1	Min. MOUNTING ROOM (mm)				
A	B	C	D	E	
2200	440	270	170	485	
2500	455	275	180	505	
2800	485	295	190	515	
3100	495	300	195	525	
3900	515	310	205	545	
4600	550	325	225	575	
5100	560	330	230	585	

wheel with the 3 nylon spacers and longer fasteners provided. Re-fit the planetary gear assembly into the ring gear.

9. Fit the chain-guide loosely to the axle, oriented with the tubes positioned vertically in-line with the chain sprockets in the chain wheel. The clamp screw is to be tightened only after final spring tensioning is completed.
10. For a planetary gear chain operator, the gear assembly and chain wheel is pushed towards the door to fully mesh with the ring gear and a $\varnothing 9.5\text{mm}$ hole is drilled through the axle using the drive hub as a guide. The chain drive is fastened with the bolt and nut provided.
11. The chain itself may be fitted now or later. Pass the chain over the chain wheel and through the chain guide. Cut an end link and bend it open to join at the desired length, then bend it closed again. Fasten the chain cleat to the drive-side wall.
12. Centre the axle by rotating a $\frac{1}{4}$ turn then releasing. Mark the axle where the drum wheel sits in the relaxed state. There should be an equal length of axle at each end.
13. Lift the roller door onto the brackets and loosely secure the axle to the brackets using two cast saddles (with the slots offset towards the door), keeper plates, and high-tensile bolts, nuts and washers at each end of the door. The lower keeper plate is fitted under the bracket.

Extreme safety warning. Safe practices must be observed when lifting roller doors as they can be very heavy. The installer must ensure the roller door is secure and supported at all times. The door is to be placed onto both brackets at the same time. The wall brackets are designed to support only a horizontal door and using them to mount door lifting gear is **not** recommended by Taurean. Any injury or damage arising from this practice will be the installer's responsibility and is **not** covered by the door warranty.

14. Centre the roller door on the axle with the same amount of curtain overlap each side and position the motor. Rocking the roller door on its axle will assist the door to move into position. Ensure the drum sits on the axle as marked in Step 12.
15. Move the door to the rear of the bracket slots and, without cutting the centre nylon strap, remove other strapping and packaging material.

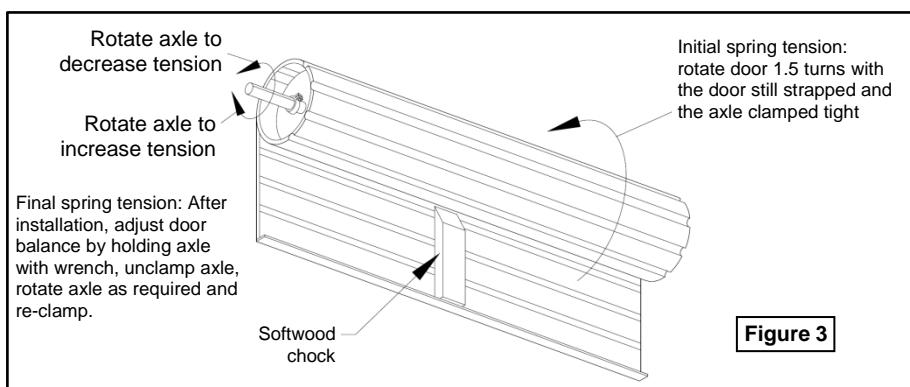

16. Turn the axle to allow the door to be relaxed on the axle with the bottom rail at the bottom of the curtain (6 o'clock position). Hold the door and give the axle a $\frac{1}{2}$ turn of tension (see Figure 3). Fully tighten the axle clamps.
17. Apply 1 turn of spring pre-tension by turning the curtain roll over the top and hold in this position (Figure 3). There is now 1.5 turns of pre-tension.
18. Without letting go of the curtain, cut the centre strap and remove packaging. Holding the centre of the bottom rail, the curtain may now be fully opened and closed to ensure the roller door is rolling up in correct alignment on the roll (ie, the ends of the rolled curtain must be square and not 'coned') prior to fitting the Guide Tracks. Take care to avoid the nylon braiding or the door curtain touching the wall.
19. The door should have a small amount of lift when in the open position and so a softwood chock may now be carefully positioned (Figure 3) between the Bottom Rail and the curtain roll to prevent the door rolling up.
20. Cut the bottom of the tracks to suit the opening height. The underside of the top stop is normally level with the top of the opening (Figure 2). The weather seal will protrude $\sim 20\text{mm}$ into the opening when the door is open. The top of the track should be at least 100mm above the wall bracket.

21. Flare out and trim both the side and rear faces at the track lead-in (Figure 4). After fitting the tracks, if necessary, adjust the angles so the curtain enters the track smoothly. If the door is installed high bend the top edge of the track away to avoid catching the nylon braiding.
22. Mount the tracks to the wall. Lower the door to the closed position and slide the tracks in from the side until there is a 3-6mm gap between the track and the black plastic button at the end of the Bottom Rail. Ensure the tracks are vertical then fix to the wall by screwing or welding as appropriate.
23. **Note:** Before fully fastening the tracks, operate the door fully to ensure it is not binding in the tracks at any point.
24. Adjust the door-axle to the optimal position on the mounting brackets. Work with the door in the open position and only loosen one end at a time. Loosen the clamp and move the door towards the wall until just about touching the track front face but avoiding any binding. Ensure both clamps are fully re-tightened (Figure 5).

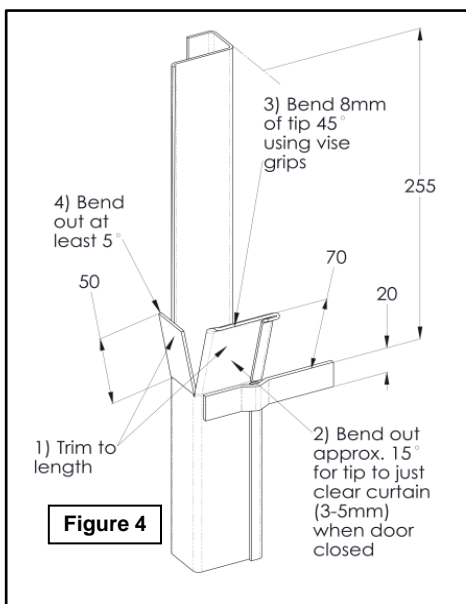

25. Install both of the optional top stop catcher brackets (Figure 6) at each end of the bottom rail using the supplied dome-head bolt and nut. Mark using the bracket as a guide and drill.

26. Check the door balance:
When correctly balanced, the roller door should have a tendency to lift slightly at the top and bottom positions and be neutral or slightly heavy at mid height.

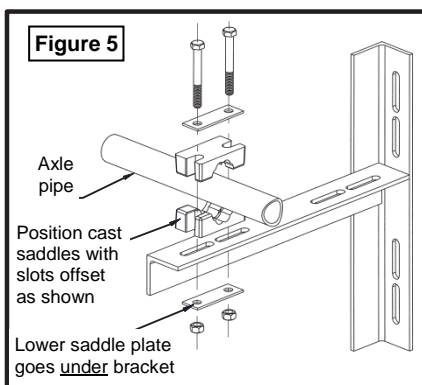

27. If necessary, adjust the springs (Figure 3):
With the door in the open position, loosen one clamp. Then, while preventing the axle from turning with a pipe wrench, loosen the other clamp. The handle of the wrench will want to lift towards the ceiling. Turn the axle in the direction required to adjust the spring tension: raise the wrench make the door 'heavier', lower to 'lighten'. This is a potentially hazardous step and should only be attempted by a competent tradesperson. Ensure both clamps bolts are fully re-tightened before operating door.

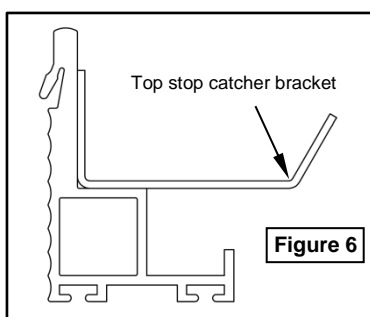

28. Complete motor installation and setup to the manufacturer's instructions.
29. Fit the optional centre lock. Remove the protective film from this area, position the lock front in the panel holes and hold or tape to the outside of the door. From the back of the door, orient the lock with the writing the 'right way up' and screw to the lock front with the 2 screws supplied.

With the door in the fully closed position, mark the height positions of the locking bar and cut a hole in each track for the locking bars to slide through.

With the lock arms fully retracted, temporarily fit the 2 locking bars to the lock arms then mark the correct length. Cut each bar to length and chamfer-cut the corners for a lead-in. Then install the locking bars through the PVC guides ensuring that any supplied anti-rattle grommets are fitted and screw them to the lock arms. Check the lock operation.

30. Remove the protective film from the outside face of the curtain.
31. Fit the optional waist-high slide-lock at a suitable height. When withdrawn the locking bar must not extend beyond the door curtain. Use the assembly as a drilling guide and attach with the rivets provided. With the door in the fully closed position, mark the height positions of the locking bar and cut a hole in each track for the locking bars to slide through.

Product Warranty

Stramit Corporation Pty Limited Roller Door Warranty and Exclusion of Liability Statement

1. This Warranty is given by:

Stramit Corporation Pty Limited trading as Taurean Door Systems (Taurean)
Level 11, Tower B Zenith Centre
821 Pacific Highway, Chatswood NSW 2067
Phone: (02) 9928 3600
Email: customerservice@taureands.com.au
Website: www.taureands.com.au

2. The benefits under this Warranty are in addition to, and in no way limit or exclude, any rights and remedies that may be available to consumers under the Australian Consumer Law.
3. Our goods come with guarantees that cannot be excluded under the Australian Consumer Law. You are entitled to a refund for a major failure and for compensation for any other reasonably foreseeable loss or damage. You are also entitled to have the goods repaired or replaced if the goods fail to be of acceptable quality and the failure does not amount to a major failure.
4. Taurean® roller door kits (**Product**) carry a **twelve-month warranty** against defects (**Warranty**) from the date of purchase of the Product which is subject to the matters set out below.
5. This Warranty applies only where:
 - (a) the purchaser seeking to rely on the Warranty presents proof of purchase to confirm the date of purchase of the Product;
 - (b) if the Product has been installed, an authorised Taurean installer (Authorised Installer) performed the installation; and
 - (c) Taurean determines, in its absolute discretion, that the Product has a defect covered by this Warranty.
6. This Warranty does not apply:
 - (a) To any defect, loss or damage arising or caused directly or indirectly by or as a result of:
 - i. Any masonry rendered or other surfaces cracking or collapsing during the installation of the Product.
 - ii. Any defects or deterioration of timber including drying after installation of the Product.
 - iii. Any weakening or collapse of the structure to which the Product is affixed occurring any time after the installation of the Product.
 - iv. Any damage to or deterioration in the condition of the Product caused by manhandling occurring after delivery and prior to installation.
 - v. Any defects (including defects in components parts or accessories) arising from or attributable to the failure to carry out preventative maintenance or adjustment to the Product in accordance with the supplied instructions.
 - vi. The continued use or operation of the Product after it is known to be defective.
 - vii. The application of any cleaning agent to the Product which is not in accordance with the supplied instructions.
 - viii. Faulty installation of the Product where such installation is not carried out by an Authorised Installer.
 - (b) To any Product that is installed within 800 metres of the sea or other body of water of equivalent or greater salt concentration or in an area subject to industrial fall out.
 - (c) To any defects to the Product that consist of paint rubs or scuffing on the internal wash coat finish or external painted finish.

7. To make a valid claim under this Warranty, a person must submit a claim in writing to Taurean at the abovementioned address **within twelve months** from the date of purchase of the Product. The claim must include:
 - (a) A copy of this Warranty;
 - (b) A description of how the Product is defective;
 - (c) The date on which the person making the claim discovered the defect;
 - (d) Proof of the date of purchase of the Product in the form of an invoice or receipt; and
 - (e) If the Product has been installed, proof of the date of installation of the Product in the form of an invoice or receipt from an Authorised Installer.
8. Where a valid Warranty claim is made in accordance with clause 7 above, Taurean will honour this Warranty by, at its absolute discretion:
 - (a) Replacing the Product; or
 - (b) Where appropriate, providing on site touch-up of 'Colorbond' or pre-painted surfaces on the Product, or
 - (c) Refunding the cost of purchasing the Product.
9. Wherever the Product is sold by any person other than Taurean, such person has no authority whatsoever from Taurean to give any express warranty or guarantee on any Taurean product in addition to this Warranty.
10. To the maximum extent permitted by law, and subject to any rights or remedies that consumers may have under the Australian Consumer Law, Taurean disclaims any liability of any nature in respect of any claim or demand for damages or costs or loss, which arises out of:
 - (a) Accidental damage or normal wear and tear to the Product or to the Product's components;
 - (b) Fire, strong winds, lightning, water damage, condensation, power supply blackout or surge, door blow in, storm damage or an act of God;
 - (c) Incorrect, improper or unreasonable maintenance and or use of the Product;
 - (d) Installation, adjustment or use of the Product, other than by Taurean or an Authorised Installer;
 - (e) Attempted or completed modifications or repairs to the Product carried out by a person who is not authorised by Taurean to carry out such modifications or repairs; or
 - (f) Preventative maintenance and regular servicing of the Product not being undertaken.
11. If during inspection by Taurean the defect in the Product is rectified by an adjustment that comes under the responsibility of the purchaser to have the Product serviced on a regular basis, a service fee will be charged by Taurean.